

HYDRAULIC RESISTANCE AND HEAT TRANSFER IN AN ANNULAR CHANNEL WITH ROTATING FLOW

A. I. Borisenko, K. F. Nechitailo,
V. A. Safonov, and A. I. Yakovlev

UDC 536.244:532.501.312

The results are given of an experimental study of the hydraulic resistance and heat transfer between the inner wall of an annulus and a rotating axial air flow through the annulus.

Investigations of the performance of some plant equipment (e.g., vortex chambers and vortex heat exchangers) encounters the problem of heat transfer between rotating flow entering an annular passage and the walls of the passage. Up to the present time there are no extensive data available for the heat transfer coefficients in this situation.

Various authors have studied either heat transfer between axial turbulent flow without rotation and the inner wall of an annulus [1] or heat transfer between flows with varying degrees of rotation and the outer wall [2, 3].

The aims of this study were to determine the heat transfer coefficients between the inner wall and rotating air flow in an annulus and to compare these with those for axial flow without rotation.

Figure 1 shows the experimental apparatus diagrammatically. The air flowed axially down the annular passage with the rotation which was produced by the tangential entry jet 1. The inner wall of the passage was of 40 mm diameter d_1 and was made of copper pipe 3 of 2 mm wall thickness. A heat fluxmeter probe 2 (of 17 mm length and 10 mm width) was fixed into the wall flush with its outer surface. Water from a heated storage tank 4 was passed through the copper pipe (thereby heating the air flow through the inner annular wall). The heat flow was measured with the fluxmeter probe in several different axial and peripheral positions of the copper pipe 3 to improve the accuracy of the experiments. These measurements were made by moving the pipe 3 axially and by rotating it. Heat loss through the outer wall of diameter $d_2 = 53$ mm of the annulus was avoided by insulation to a diameter $d_2 = 78$ mm.

The heat fluxmeter was calibrated radiometrically after installation as previously described [4]. The heat flux q was determined after allowing for the resistance introduced by the probe [4]. This correction was evaluated from the 0.1 mm thermocouple 6,7 placed in the pipe wall under the probe and in the copper plate 8 over the probe. Provision was also made for introducing the flow into the annulus without rotation. This was achieved by passing the air into the annular receiver before it entered the annulus through a contracting section.

The air flow rate was varied by adjusting the entrance pressure and was measured by the orifice plate 10. The local heat transfer coefficient α at a distance x from the entry to the annulus was determined as follows

$$\alpha_x = \frac{q_x}{t_{sx} - t_{vx}}, \quad (1)$$

where q_x is the local heat flux measured by the probe; t_{sx} is the wall temperature; $t_{v,x}$ is the mean air temperature at x from the entry. The value of $t_{v,x}$ was calculated from

$$(t_{vx} - t_{v0}) C_p G = \pi d \int_0^x q_x dx, \quad (2)$$

Kharkov Aviation Institute. Translated from *Inzhenerno-Fizicheskii Zhurnal*, Vol. 21, No. 1 pp. 38-42, July, 1971. Original article submitted July 21, 1970.

© 1973 Consultants Bureau, a division of Plenum Publishing Corporation, 227 West 17th Street, New York, N. Y. 10011. All rights reserved. This article cannot be reproduced for any purpose whatsoever without permission of the publisher. A copy of this article is available from the publisher for \$15.00.

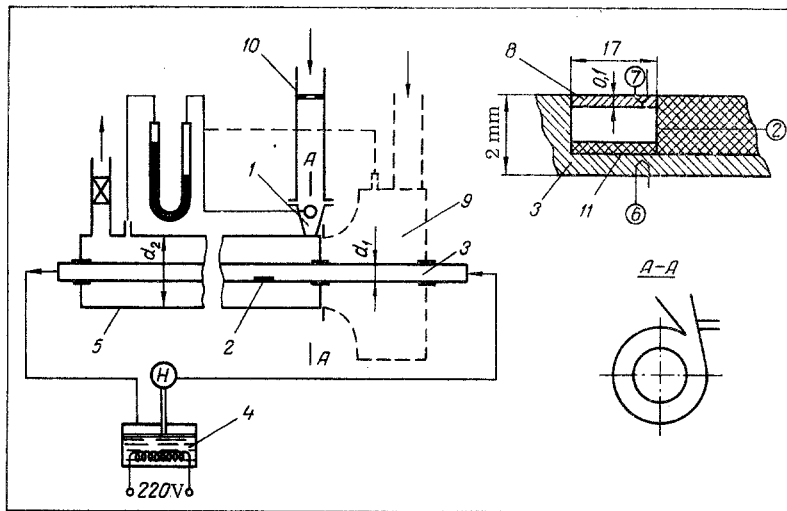

Fig. 1

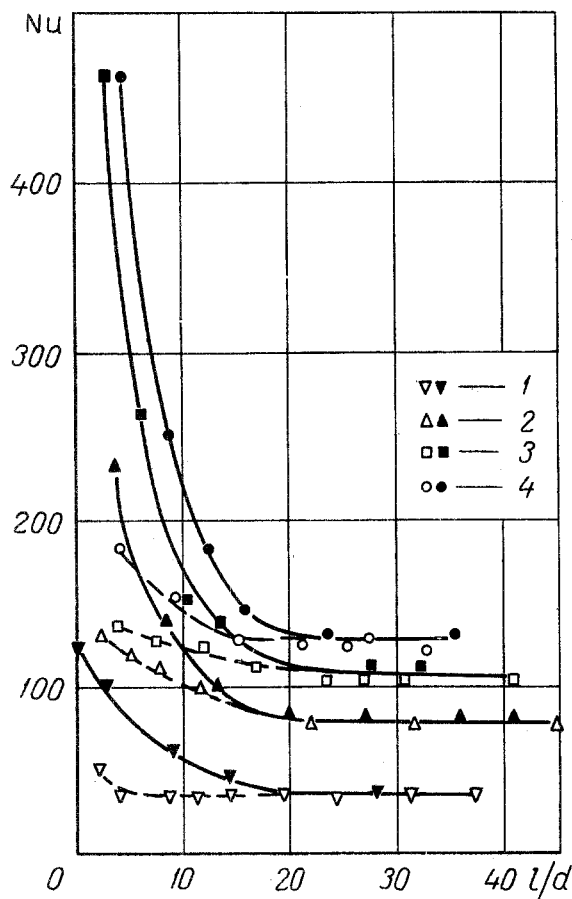

Fig. 2

where t_{v0} is the air temperature at the entry to the heated section (measured by thermocouple); C_p is the specific heat of the air; $\int_0^x q_x dx$ is the area under the graph of $q_x = q_x(x)$ obtained from the probe data for the upstream parts of the heat exchange area.

The accuracy of this procedure for determining the mean air temperature was checked at $x = 1$ by comparing the calculated value of $t_{v,x}$ with the value t_{out} measured by thermocouple at the exit from the heated section. The discrepancy between these values did not exceed 5%. The temperature $t_{v,x}$ was taken as a criterion of temperature for comparing various data. The length $d = d_2 - d_1$ was taken as a typical dimension. The experimental results were then computer processed to obtain nondimensional ratios in the form $Nu = Nu(Re; x/d; d_1/d_2)$ shown in Fig. 2. (The Grashof number Gr was not included in the analysis because previous results [2] had shown it to have no significant effect on the inertia forces.) The dashed lines show the results for flow without rotation. At distances $x \geq 18-20 d$ the effect of the initial rotation on the heat transfer has become insignificant and the experimental results are in good agreement with the nondimensional relations obtained previously [1] for axial flow in an annular passage

$$Nu_0 = 0.017 Re^{0.8} Pr^{0.4} \left(\frac{d_2}{d_1} \right)^{0.18}$$

Figure 2 shows that with decrease in distance from

the entry of the flow with rotation, the heat exchange increases rapidly and the heat transfer coefficients are 2-4 times larger than those for axial flow.

Further analysis of the data in Fig. 2 to present it in the form $(Nu_\omega/Nu_0 = f(l/d))$ (Fig. 3), where Nu_ω is the Nusselt number for the flow with rotation and Nu_0 is the Nusselt number for axial flow from the data [1] shows the generalized relationship for the local Nu for short passages ($l/d \approx 2-20$). The experimental results are well represented by the dashed line (Fig. 3) which fits the equation

$$Nu_\omega = Nu_0 \left(1 + 2.662e^{-0.196 \frac{l}{d}} \right)$$

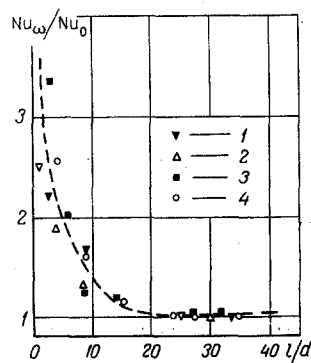

Fig. 3

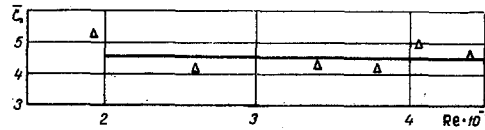

Fig. 4

The stabilizing effect of the rotation in the flow on the heat transfer from the inner wall should be noted. During the experiments the air temperature was obtained along various radii and around the circumference at several sections. The axial length of stabilized temperatures approximates to the axial length of stabilized heat transfer coefficients. The greatly enhanced heat transfer in the upstream length of the annulus can however be accounted for to only a small extent by the increased temperature difference between the inner wall and the air in the vicinity of this wall.

Some data on the effect of the rotation in the flow on the hydraulic resistance were also obtained. Total pressure losses ΔP^0 were estimated from the air flow and the static pressures in the nozzle 1, and the end of the annular passage where the rotation has almost ceased:

$$\zeta = \frac{\Delta P^0}{\rho^0}$$

The coefficient of total pressure drop ζ thus obtained includes losses in both the passage and the entry chamber. (The exit area of the nozzle 1 was 1/3 of the cross-sectional area of the annulus.) Figure 4 shows the ratio $\bar{\zeta} = \zeta(\text{Re})$, where $\bar{\zeta}$ is the ratio of pressure loss coefficient for flow with rotation and for axial flow, and Re was calculated from the average velocity in the passage.

For value of Re the pressure losses in the heat exchanger section were found to be about 4.5 time greater than those for axial flow. This result together with the above heat transfer data enable the effectiveness of rotation in the flow to be determined for heat exchangers.

NOTATION

- d_1 is the inner surface of annular channel;
- d_2 is the outer surface of annular channel;
- q is the heat flux;
- G is the air flow rate;
- α is the heat transfer coefficient;
- t is the temperature;
- P is the pressure;
- C_p is the air heat capacity at constant pressure;
- l is the channel length.

LITERATURE CITED

1. V. P. Isachenko and N. M. Galin, in Collection: Trudy MĖI, Moscow (1965).
2. A. A. Kuznetsov and A. V. Sudarev, Ėnergomashinostroenie, No. 1 (1968).
3. V. Yu. Shchukin, Izv. Vuzov, Aviatsionnaya Tekhnika, No. 2 (1967).
4. O. S. Gerashchenko, V. G. Karpenko, and Yu. M. Chimisov, in: Convection Heat Transfer [in Russian], Naukova Dumka, Kiev (1968).